

AFA 1000

FUME CUPBOARD MONITORS

Operating and Instruction Manual



Model AFA1000 / 1 – Mk2

- Digital display
- 3 Relay inputs
- 3 Relay outputs
- Com port

Used for alarm indication and monitoring on Fume Cupboards



Model AFA1000 / 2 – Mk2

- Digital display
- 3 Relay inputs
- 3 Relay outputs
- 3 Pushbuttons
- Com port

Used for alarm indication , monitoring and control on Fume Cupboards

Issue: Jan 08

OPERATOR DISPLAY PANEL

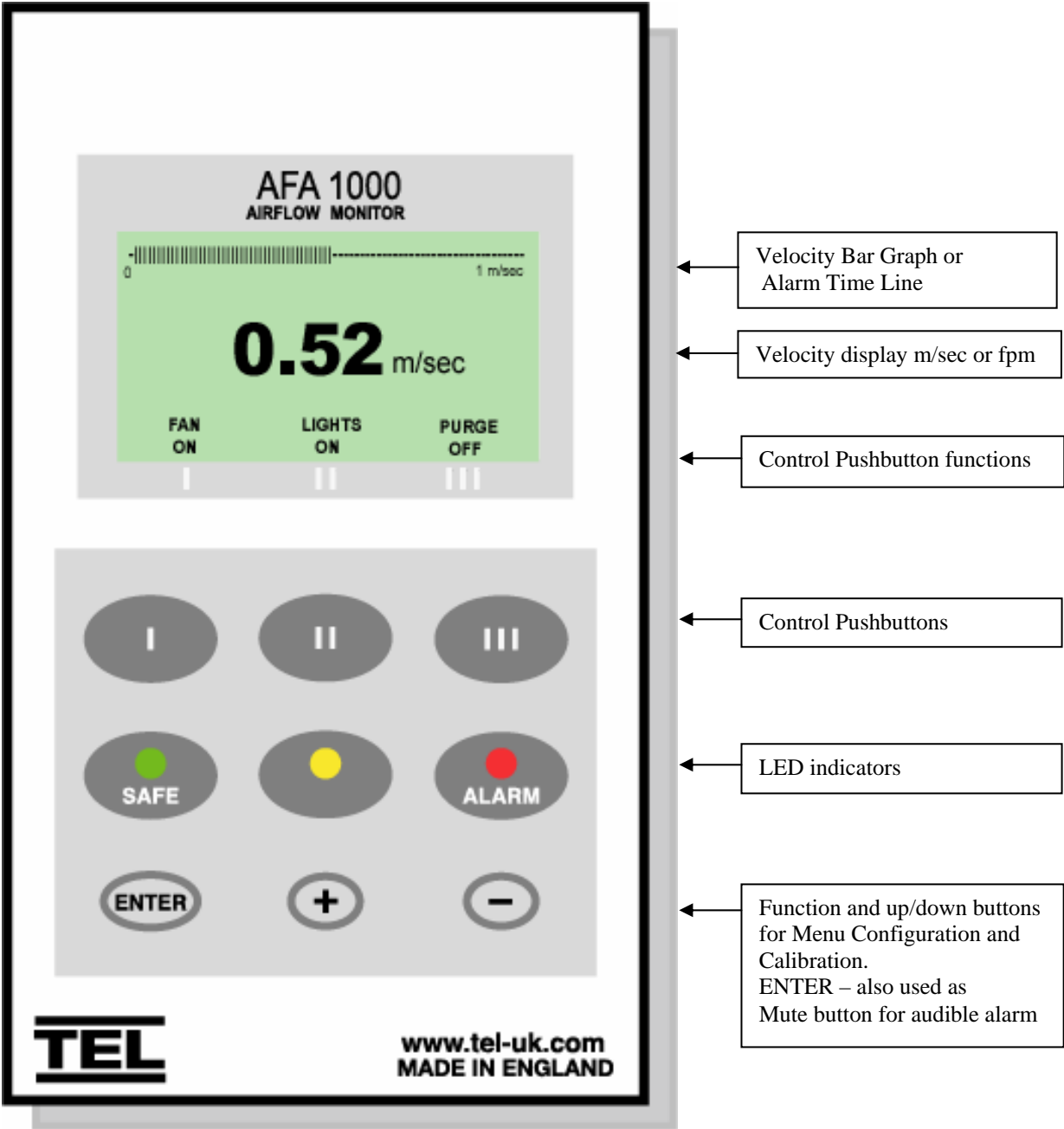

Note :- Access to the Calibration and Configuration menus is password protected and is factory set. To access and or change the password contact the supplier for the Engineers Password and enter the Passwords in the Main Menu or alternatively use a Laptop connected to the Com port and the Upload/Download software provided

Connection details :-

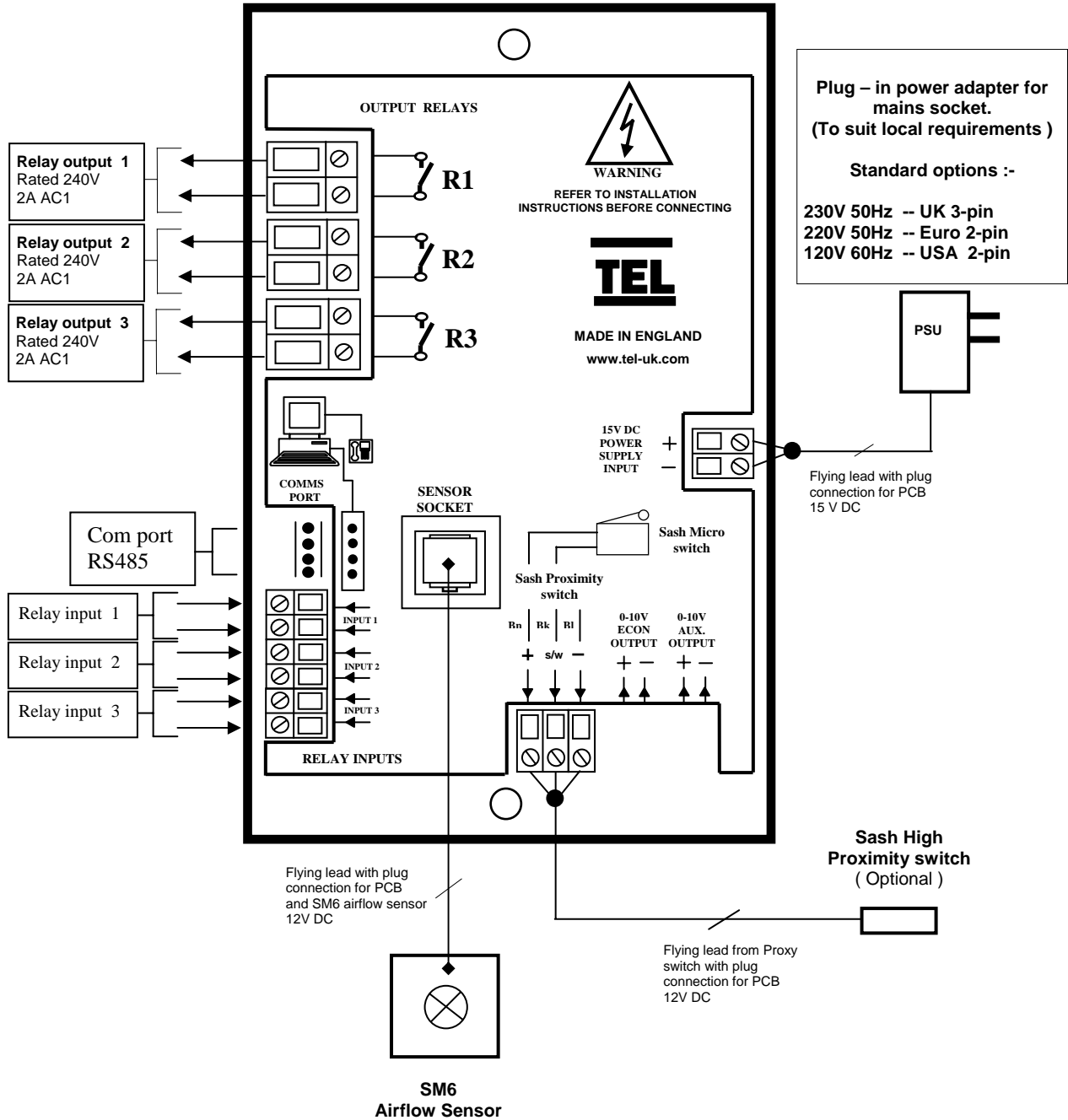

1.1 General Description

All systems comprise of the following components :-

- 1 – SM6 Airflow Sensor,
- 1 – AFA1000 Alarm unit,
- 1 – DC power supply

If the Sash Alarm System option is included there will also be a sash micro switch or proximity switch.

Operator Features --- the alarm has the following operator features :-

Digital Display

The digital display is a back-lit, full graphic unit with a visual display of approx 56 x 27 mm. The display operates through the software allowing the generation of figures, wording and icons.

The display shows the fume cupboard face velocity in **m/sec** or **fpm** when enabled or the alternative with no velocity reading but showing **AIR FAIL / AIR SAFE** as continuous display. All of the above are configurable via the alarm key pad.

An ' **event time line** ' segmented into 20 x 3 minute segments will scroll across the display (when enabled) .This takes the form of a graphical ' blip' that will progress from the right hand side to the left hand side – representing events that have occurred during the past hour. The alternative to the event time line is a dynamic ' **bar graph** ' representing the face velocity

The display shows a **Horn** icon (with line through it) when the audible alarm is in the Muted condition

Sash High – will be displayed when the Sash alarm is enabled and the sash is raised above the max safe working opening.
This display will alternate on/off with the velocity reading.

Ext Alarm – will be displayed when the external alarm input is activated (when enabled)
This display will alternate on/off with the velocity reading

Air Fail - will be displayed if the airflow is less than the Low air alarm point.
This display will alternate on/off with the velocity reading

High Air - will be displayed if the airflow is more than the High air alarm point.
This display will alternate on/off with the velocity reading

Set-back - will be displayed if the night set-back function is activated (when enabled)
This display will alternate on/off with the velocity reading

Disabled - will be displayed if the alarm disable function is activated (when enabled)
This display will alternate on/off with the velocity reading

LED Indicators ---- the alarm unit has three LED indicators :-

Red -- Alarm
Amber -- Caution
Green -- Safe

Audible Alarm sounder -- the alarm has an audible alarm sounder with local or remote Mute facility

Enter --- the alarm has an Enter button -- this is multi-functional as follows :-

Press **Enter** momentarily when alarm is sounding will mute the alarm

Press **Enter** for 5 secs will gain access to **Calibration** and **Configuration** menus (both menus password protected)

+ / - -- the alarm has + / - buttons that can be used to scroll through the calibration and configuration menu or to select options or values

External Connections -- the alarm unit will have the following connection points :-

Input 1 --- volt free relay input configurable for normally closed or normally open relays

This input can be configured as :-

Alarm disable
Night set-back
External alarm
Sash High
High / Low

Input 2 --- volt free relay input configurable for normally closed or normally open relays

This input can be configured as :-

Alarm disable
Night set-back
External alarm
Sash High
High / Low

Input 3 --- volt free relay input configurable for normally closed or normally open relays

This input can be configured as :-

Alarm disable
Night set-back
External alarm
Sash High
High / Low

Output 1 --- volt free relay output configurable as normally closed or normally open relays.

Output 2 --- volt free relay output configurable as normally closed or normally open relays.

Output 3 --- volt free relay output configurable as normally closed or normally open relays.

Com Port --- RS 485 to enable connection to Laptop or PC for full diagnostics , logging or setting up and for communications to building computer system (BMS)

Power supply --- low voltage DC power supply

Airflow Sensor --- connection socket for the face velocity airflow sensor.

The following Pushbutton controls apply to the AFA1000 / 2 only :-

Pushbutton 1 -- This button can be configured to act as a **Fan stop / start** button for the fume cupboard extract fan or as **Night Set-back Override**

Pushbutton 2 --This button can be configured to act as a **Lights ON / OFF** or **UV Lights On/OFF** for the fume cupboard or **Pump stop / start** button for a fume cupboard scrubber pump.
(Can be interlocked with Pushbutton 1)

Pushbutton 3 -- This button can be configured to act as a **Panic** button or a **Purge button**.

Fan ON / OFF -- will be displayed if the Fan button is operated (when enabled).

Lights ON / OFF -- will be displayed if the Lights button is operated (when enabled).

Pump ON / OFF -- will be displayed if the Pump button is operated (when enabled).

UV Lights ON / OFF -- will be displayed if the UV Lights button is operated (when enabled).

Purge ON / OFF -- will be displayed if the Purge button is operated (when enabled).

See **Menu Block Diagram** document for other specific operations and indications.

1.2 Alarm Configuration / Calibration

The alarm can be configured via a Laptop or PC using a variety of 'set up' programs each designed for a particular application with a combination of inputs, outputs and push buttons. This configuration can be changed via the alarm key pad using the menu system if required or re-configured by re-connection of the laptop or PC.

This allows the fume cupboard manufacturer to stock standard units and configure the alarms to suit the application.

The configuration of the various functions and the calibration of the alarm face velocity display is menu driven. Access to the menu will be via password (4 digit number) and will be two level. The first level will be for calibration of the unit and the second level will be for 'engineers' to set up the configuration of the alarm.

**NOTE:- If you enter the Calibration or Configure Menu by accident :-
press the + & - buttons at the same time to escape back to the Main Menu**

The menus and sub-menus are in ' plain language ' and incorporate brief instructions where appropriate.

See **Menu Block Diagram** operation document

1.3 Start up

When unit is powered up the following sequence of events occur :-

1. The 12V DC power is applied to the airflow sensor and a delay on timer is initiated.
2. The alarm then performs a self test on the display and all indicators etc (approx 5 sec)
3. At the end of the delay period the unit performs one of two options :-
 - a. If the alarm calibration has been previously completed – the unit goes to normal operating mode (Run)
 - b. If the unit has not been calibrated the unit displays
' Unit requires Set up -- press Enter to access Set up menu '
The set up menu allows calibration or configuration via the password protection

During the set-up all alarms and output relays are inhibited.

1.4 Events / actions

Safe airflow

- Meter reading above warning level (eg > 0.45 m/sec)
- Green LED on

Warning airflow

- Meter reads between warning level and air fail level (eg > 0.40m/sec and < 0.45 m/sec)
- Amber LED on

Low airflow

- Meter reads below alarm level for longer than the warning to low air delay time
- **AIR FAIL** toggles on / off with display
- Red LED on (Flashing)
- Audible alarm sounds -- can be muted via Enter pushbutton
- Low air relay operates (if configured)

Reset : -- when airflow rises 0.02m/sec above Low air level for longer than the low air to warning air delay time the Low air alarm resets automatically

High airflow

If configured :-

- **High Air** toggles on / off with display
- Audible alarm sounds – can be muted via Enter pushbutton)

Audible alarm Mute

- When the audible alarm is muted via the Enter button - an Icon (horn with forward slash) is shown on the display.

Sash High

- When the input configured as Sash High is activated
- Amber LED on
- **Sash High** – toggles on / off with velocity display
- Audible alarm sounds
- Audible can be muted via Enter pushbutton -- this silences the alarm and initiates a repeat timer (if configured). After the delay time the alarm re-sounds (and can be re-muted). During this time the Amber LED flashes on / off.
- Sash High relay operates (if configured)

Reset when Sash lowered to safe position and input de-activated.

High / Low

- When input configured as High/Low is activated
- Display Icon shows **High** or **Low**
- High / Low relay operates (if configured)

This function is designed for two speed fan operation or two position damper operation switched via a micro switch or proximity switch activated at a given position on the sash.

Night set-back

- When input configured as Night set-back is activated
- Night **Set-Back** Icon is displayed
- Red LED on (Flashing)
- Reduced Low air alarm (if configured)
- Audible alarm muted
- Mute Icon shown on display

External alarm

- When input configured as External alarm is activated
- Red LED on (Flashing) – (if configured)
- **External Alarm** toggles on /off with display -- (if configured)
- Audible alarm sounds – can be muted via Enter pushbutton
- External alarm relay operates (if configured)

Alarm disable

- When input configured as Alarm disable is activated
- **Alarm disabled** is displayed
- Red LED on (Flashing)
- Audible alarm muted
- Mute Icon shown on display

AFA1000/2 - only

Pushbutton 1 -- Fan Stop / Start

- Fan start relay operates
- Display shows **Fan On/Off**
- Run up timer for 2nd relay – Amber LED flashes on / off (if configured)
- Run down timer for fan start relay --- Amber LED flashes on / off (if configured)
- Interlock with Pushbutton 2 (if configured)

or

Pushbutton 1 -- Override On / Off

- Relay operates (if configured)
- Red LED flashes on/off
- Audible alarm muted
- Meter displays **Override On/Off**
- Disables Night setback operation in **Override On** condition

Note:- In the **On** condition the unit ignores any Night Set-back input signals and remains in this condition until **Off** is selected

Pushbutton 2 -- Pump On / Off , Light On / Off , UV Light On / Off ,

- Relay operates
- Pump , Lights , UV Lights Icon shown on display (if configured)
- Interlock with Pushbutton 1 (if configured)

Pushbutton 3 -- Purge On/Off

- Relay operates -- (if configured)
- Red LED on (Flashing) – (if configured)
- **Emergency** toggles on /off with display -- (if configured)
- Audible alarm sounds -- can be muted via Enter pushbutton
- Extract output goes to Max if used with Damper or Inverter drives

2.1 Quick Start Installation

Follow the instructions below for installing and commissioning the unit. :-

1. Fit the alarm to the Fume Cupboard using the cut-out details provided with the unit --- see page 13
2. Fit the airflow sensor to the Fume Cupboard using the cut out and installation details provided --- see page 13 & 14
3. Connect the 'telephone style' airflow sensor plug-in cable to the sensor and the back of the alarm unit --- see typical connection diagram on page 15 & 16
4. Plug in the power adapter to a Mains AC power socket and connect the flying lead to the alarm unit --- see typical connection diagram on page 15 & 16
5. Power up the unit and wait at least 30 secs while the sensor temperature stabilises.
6. If the unit has not been calibrated the unit will display ' Requires setup ' – press ENTER to continue and in the Main Menu use the +/- buttons on the alarm facia select ' SETUP ' and then press the ENTER button.
7. In the Setup Menu select 'CALIBRATION' and press the ENTER button
8. At this stage you will be requested to enter the PASSWORD. Use the +/- buttons to select the individual digits in turn and then press ENTER.
If the password is correct the unit will go to the calibration mode. If the password is not correct you will be requested to try again --- on the third wrong password entry the calibration menu will lock out for 10 mins
9. When in the calibration mode follow the instructions on the display screen to carry out the calibration of the unit. See 'Calibration Notes' below for hints on successful calibration.
When the calibration is complete the unit will return to the Main Menu.
10. Use the +/- buttons on the alarm facia select ' RUN ' and then press the ENTER button.

The unit will now function and display the measured Fume Cupboard face velocity

2.2 Calibration Notes :-

1. When using a standard Fume Cupboard with Vertical Sliding sashes open the sash to the normal max safe working height for the Low Air sample.
2. For the Higher Air sample close the sash to approx 50% of the opening used for the Lower Air sample. If the Higher air sample value is too close to the Lower Air sample the alarm will detect this and ask you to repeat with a higher value.(The min difference between the Low & High air samples is set to 0.3 m/sec)To do this close the sash a little more and repeat the sample. Avoid closing the sash below 150mm.
3. The face velocity readings on the open sash may vary at different points on the measuring grid by up to 0.1m/sec. This is quite acceptable in terms of the fume cupboard performance so long as no individual point is below the designated Low Air alarm point .The figure entered for the calibration point can be taken as the average value of all the measuring grid readings or could be taken as the individual lowest point on the grid. For most fume cupboards this low point is on the bottom row in the centre and is a convenient position to measure and for future reference when checking the alarm during annual maintenance.
4. Take time when measuring the face velocities for the calibration procedure to allow for the velocities across the open sash to stabilise. If the velocities are changing or are turbulent during the sampling period the alarm will detect this and ask you to repeat the sample.
5. When using a Fume Cupboard with Horizontal Sliding sashes open the sashes to the normal max safe working opening for the Low Air sample.
6. When calibrating or re-calibrating the alarm it is important to ensure that the 'Vent kit' is connected to the SM6 sensor on the fume cupboard. If the vent kit is not connected the sensor will not 'see' a change in the airflow during the calibration procedure and will show "Sensor Difference too low - Check sensor". This only applies during the calibration mode. If in normal running after successful calibration the vent kit becomes disconnected the air flow across the sensor will fall and the alarm will go into the AIR FAIL condition.

3.0 Dimensions

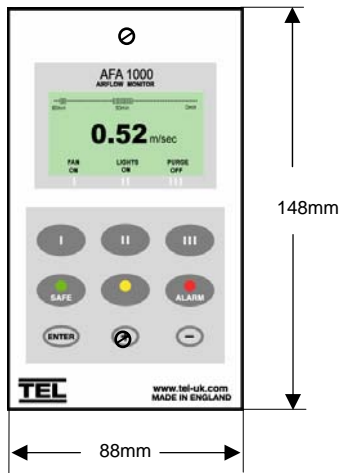

Alarm Panel Dimensions

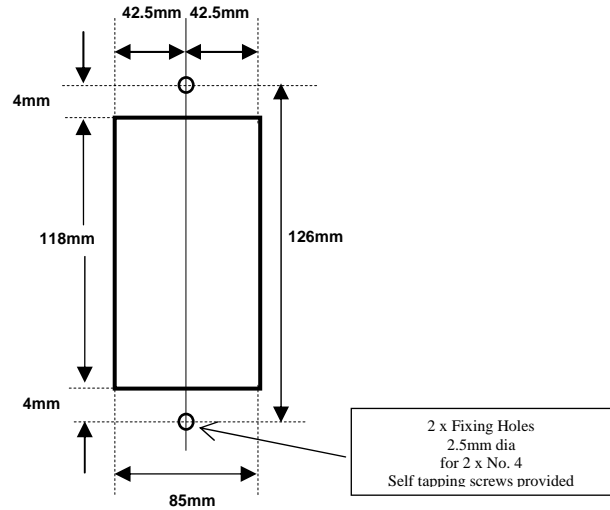

Panel Cutout Dimensions
118mm x 85mm

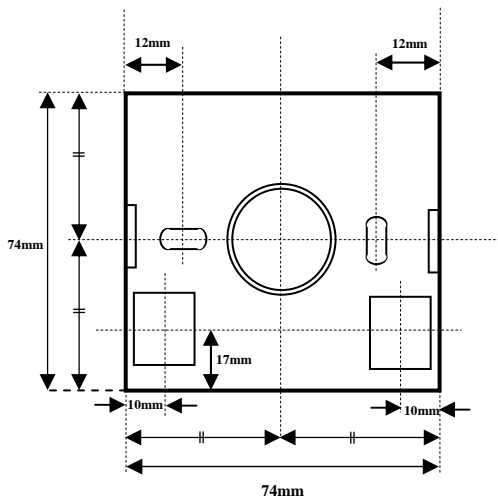

SM6 Sensor Dimensions (Rear view)

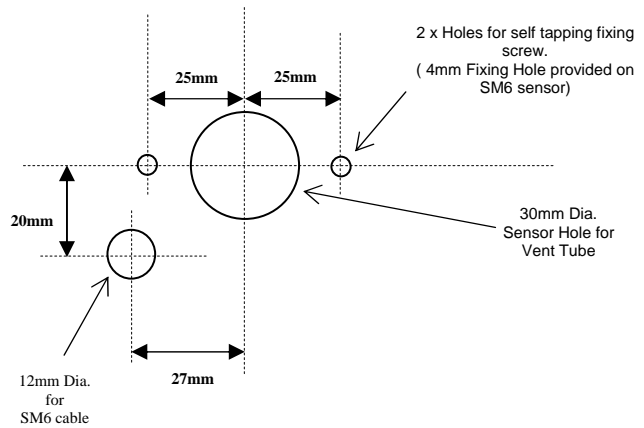

SM6 Sensor Panel Cutout Dimensions (Front view)

NOT TO SCALE

4.0 SM6 Airflow Sensor Installation

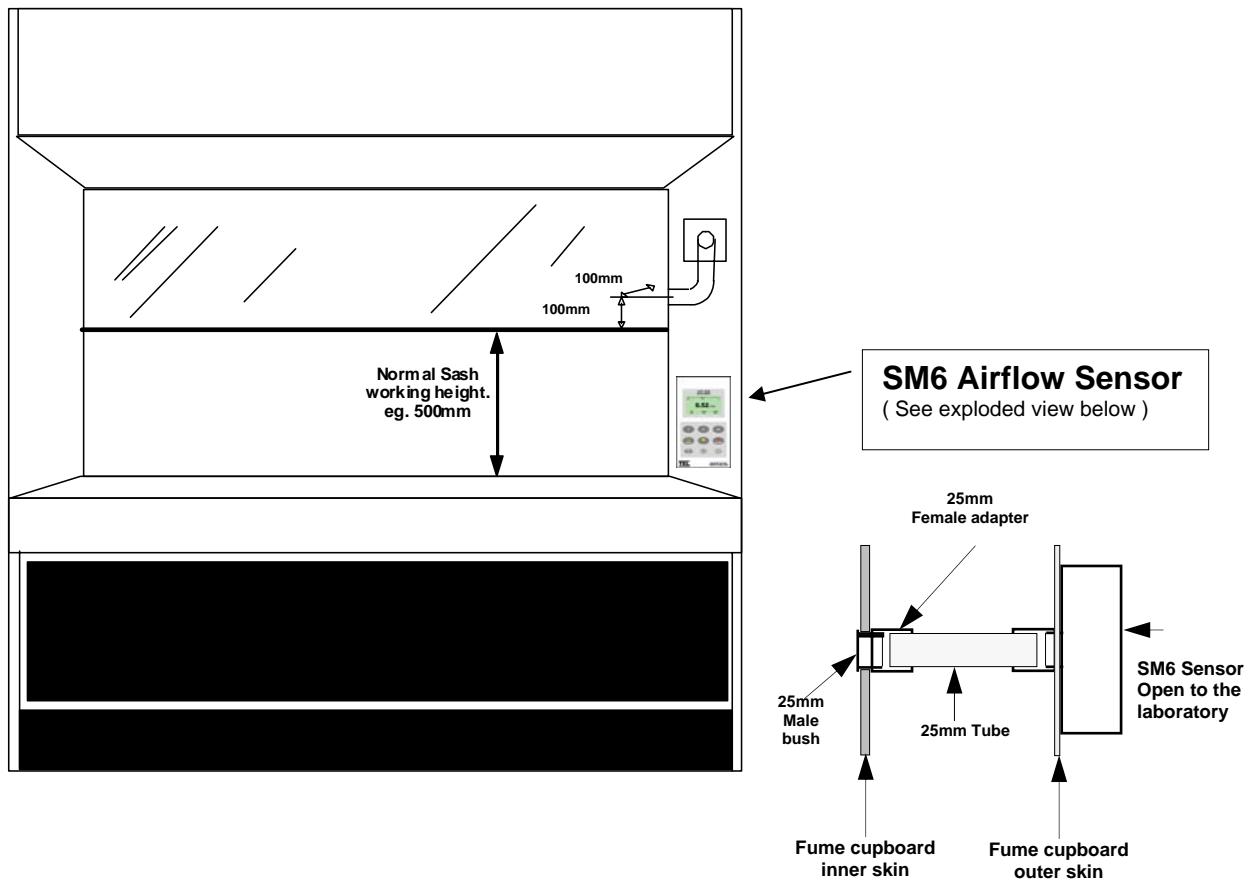

It is very important to position the SM6 airflow sensor in the correct position to give long term stable reading of the face velocity. Please read the INSTALLATION NOTES below and if in doubt contact us for further advice.

INSTALLATION NOTES :-

1. The SM6 sensor must be positioned where it can " see " the room pressure of the laboratory. The back connection spigot of the sensor is designed to accept a 25mm OD tube which should be connected to the inner chamber of the fume cupboard. (This tube and fittings is known as the " vent kit ")
The **ideal position** for the end of the 25mm tube for most fume cupboards is 100mm back from the sash glass and 100mm higher than the normal sash opening height through the inner side wall.
2. If possible mount the sensor on the front of the fume cupboard and use a short length of tube. Tube lengths of more than 1metre or smaller diameter will restrict the airflow through the sensor. This will lead to too much sensitivity being required to calibrate the unit which can lead to some instability of the reading or incorrect readings at low velocities!
3. For fume cupboards with a single skin side wall or a double skin with a small gap between them it may not be possible to achieve the ideal sensing position using a flexible tube.
With a single skin side wall it is possible to fix the sensor on the outside of the fume cupboard and connect directly to the inner chamber in the ideal position. This method can only be used for up to two fume cupboards when they are positioned side by side (using the two outer walls).
An alternative method is to mount the sensor on the front of the fume cupboard and connect using a short flexible tube to a rigid wall tube attached to the inner side wall. The open end of this rigid wall tube should be positioned in the 'ideal position' ie. 100mm back from the sash and 100mm higher than the normal sash opening.
Fume cupboards with a high internal height can present a difficulty because the tube length to reach the ideal position may be longer than 1 metre. In this case it is better to use a tube no longer than 1 metre which may result in a sensing position higher than the ideal.
When fitting a sensor to a 'narrow wall' fume cupboard for the first time it may be necessary to try various combinations of rigid and flexible tube to find the best combination and position.
4. The sensor should not be mounted in a position were it is subject to draughts from the laboratory air input or ventilation system.

5.0 Typical Wiring Diagram --- (Alarm only)

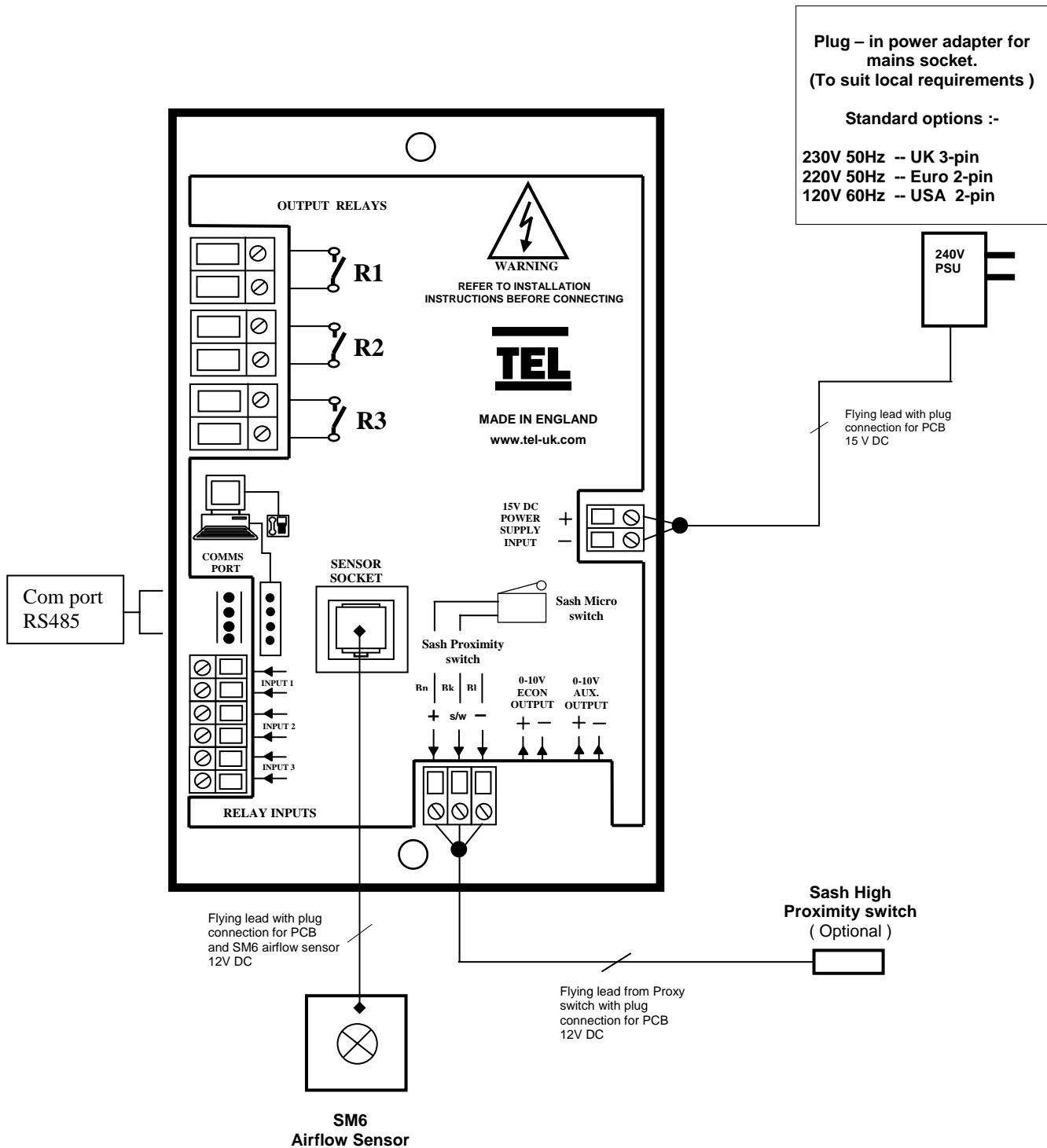

5.1 Typical Wiring Diagram with Optional Relay Interface Unit

Optional **Relay Interface Unit** in ABS enclosure mounted on top of Fume Cupboard to allow up to 3 external cable connections to be terminated. Rated at 240V 5A

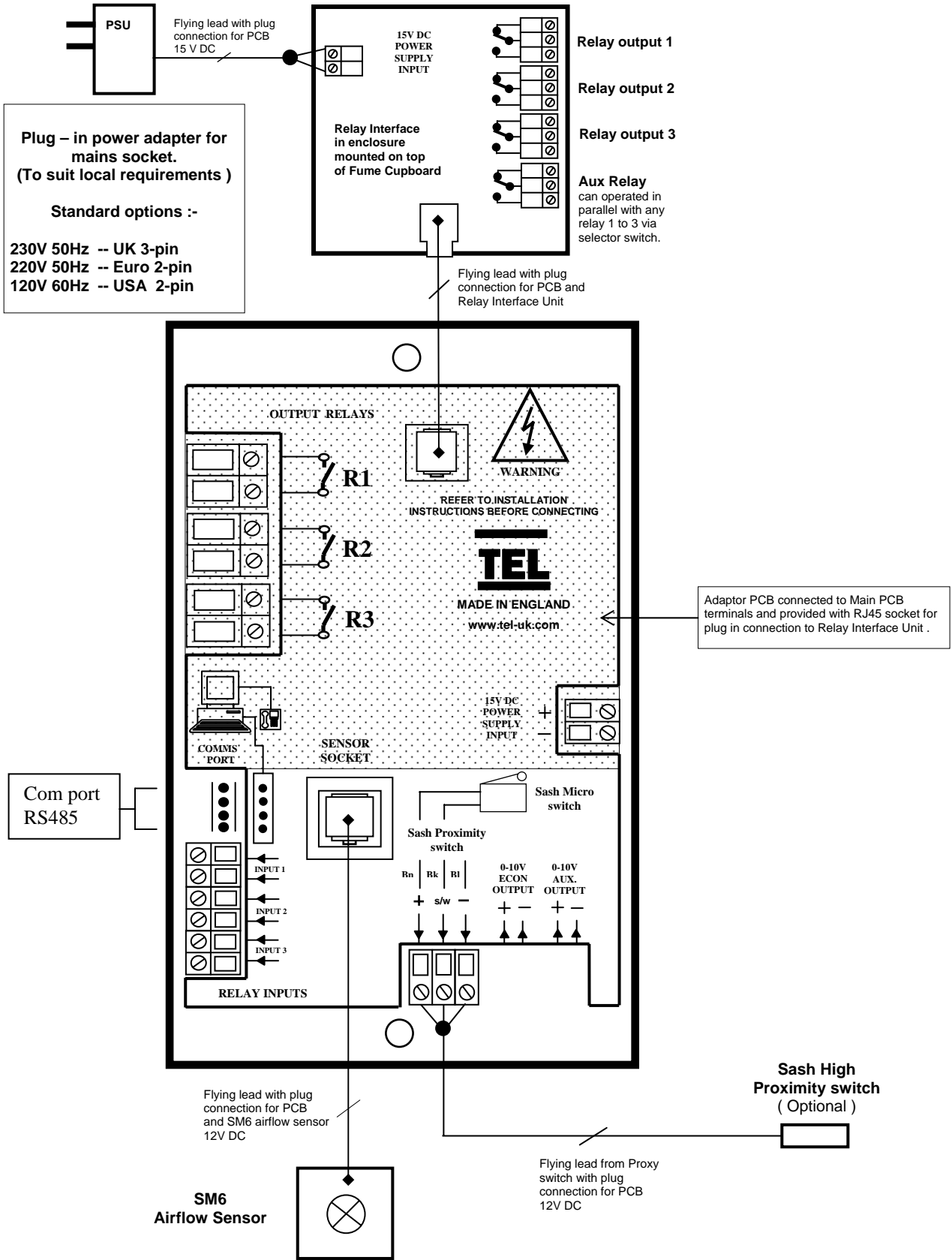

6.0 LIMITATION OF WARRANTY AND LIABILITY

Seller warrants that this product, under normal use and service as described in the operator's manual shall be free from defects in workmanship and material for a period of twelve (12) months, or the length of time specified in the operator's manual, from the date of shipment to the customer. This limited warranty is subject to the following exclusion :-

- a. Batteries and certain other components when indicated in specifications are warranted for a period of 90 days from the date of shipment to the customer.
- b. With respect to any repair services rendered, Seller warrants that the parts repaired or replaced will be free from defects in workmanship and material, under normal use, for a period of 90 days from the date of shipment to the customer
- c. Seller does not provide any warranty on finished goods manufactured by others. Only the original manufacturer's warranty applies.
- d. Unless specifically authorised in a separate writing by Seller, Seller makes no warranty with respect to, and shall have no liability in connection with, any goods which are incorporated into other products or equipment by the Buyer. All goods returned under warranty shall be at the Buyer's risk of loss, Seller's factory prepaid, and will be returned at Seller's risk of loss, Buyer's factory prepaid.

The foregoing is IN LIEU OF all other warranties and is subject to the conditions and LIMITATIONS stated herein. NO OTHER EXPRESS OR IMPLIED WARRANTY OF FITNESS FOR PARTICULAR PURPOSE OR MERCHANTABILITY IS MADE.

THE EXCLUSIVE REMEDY OF THE USER OR PURCHASER, AND THE LIMIT OF LIABILITY OF SELLER FOR ANY AND ALL LOSSES, INJURIES, OR DAMAGES IN CONNECTION WITH THIS PRODUCT (INCLUDING CLAIMS BASED ON CONTRACT NEGLIGENCE, STRICT LIABILITY, OTHER TORT, OR OTHERWISE) SHALL BE THE RETURN OF THE PRODUCT TO THE FACTORY OR DESIGNATED LOCATION AND THE REFUND OF THE PURCHASE PRICE, OR, AT THE OPTION OF THE SELLER, THE REPAIR OR REPLACEMENT OF THE PRODUCT. IN NO EVENT SHALL SELLER BE LIABLE FOR ANY SPECIAL, INCIDENTAL OR CONSEQUENTIAL DAMAGES. SELLER SHALL NOT BE RESPONSIBLE FOR INSTALLATION, DISMANTLING, REASSEMBLY OR REINSTALLATION COSTS OR CHARGES. NO ACTION, REGARDLESS OF FORM, MAY BE BROUGHT AGAINST THE SELLER MORE THAN ONE YEAR AFTER THE CAUSE OF ACTION HAS ACCRUED.

The purchaser and all users are deemed to have accepted the terms of this LIMITATION OF WARRANTY AND LIABILITY, which contains the complete and exclusive limited warranty of Seller. This LIMITATION OF WARRANTY AND LIABILITY may not be amended or modified nor may any of its terms be waived except by a writing signed by an authorised representative of the Seller.

7.0 Contact us :-

For further information on our range of airflow alarms and controls please contact us at :-



TEMPERATURE ELECTRONICS Ltd

388 / 400 MANCHESTER ROAD

ROCHDALE

LANCS , ENGLAND

OL11 4NW

Tel : +44 1706 633438 Fax : +44 1706 524609

Web site: www.tel-uk.com