

AFA 1000/E/Bld

Fume Cupboard Extract Fresh Air Bleed / Room Air Bleed Controller Operating and Instruction Manual

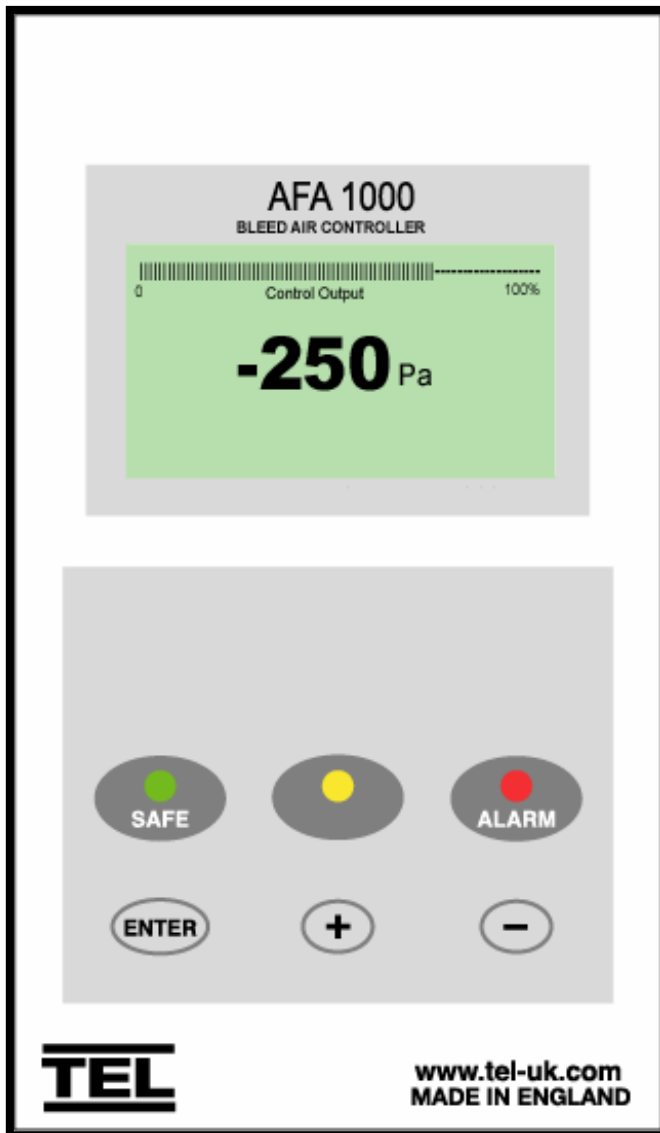

Model AFA1000 / E / Bld

- Digital display
- 3 Relay inputs
- 3 Relay outputs
- Com port
- Control output

Used for alarm indication and control of extract system
Fresh Air Bleed for :-
Fume Cupboards with VAV control.

Issue: Jan 08

OPERATOR DISPLAY PANEL



Control Output Bar Graph or Alarm Time Line

Pressure display Pa or ins Wg

LED indicators

Function and up/down buttons for Menu Configuration and Calibration.
ENTER – also used as Mute button for audible alarm

Note :- Access to the Calibration and Configuration menus is password protected and is factory set. To access and or change the password contact the supplier for the Engineers Password and enter the Passwords in the Main Menu or alternatively use a Laptop connected to the Com port and the Upload/Download software provided

Connection details :-

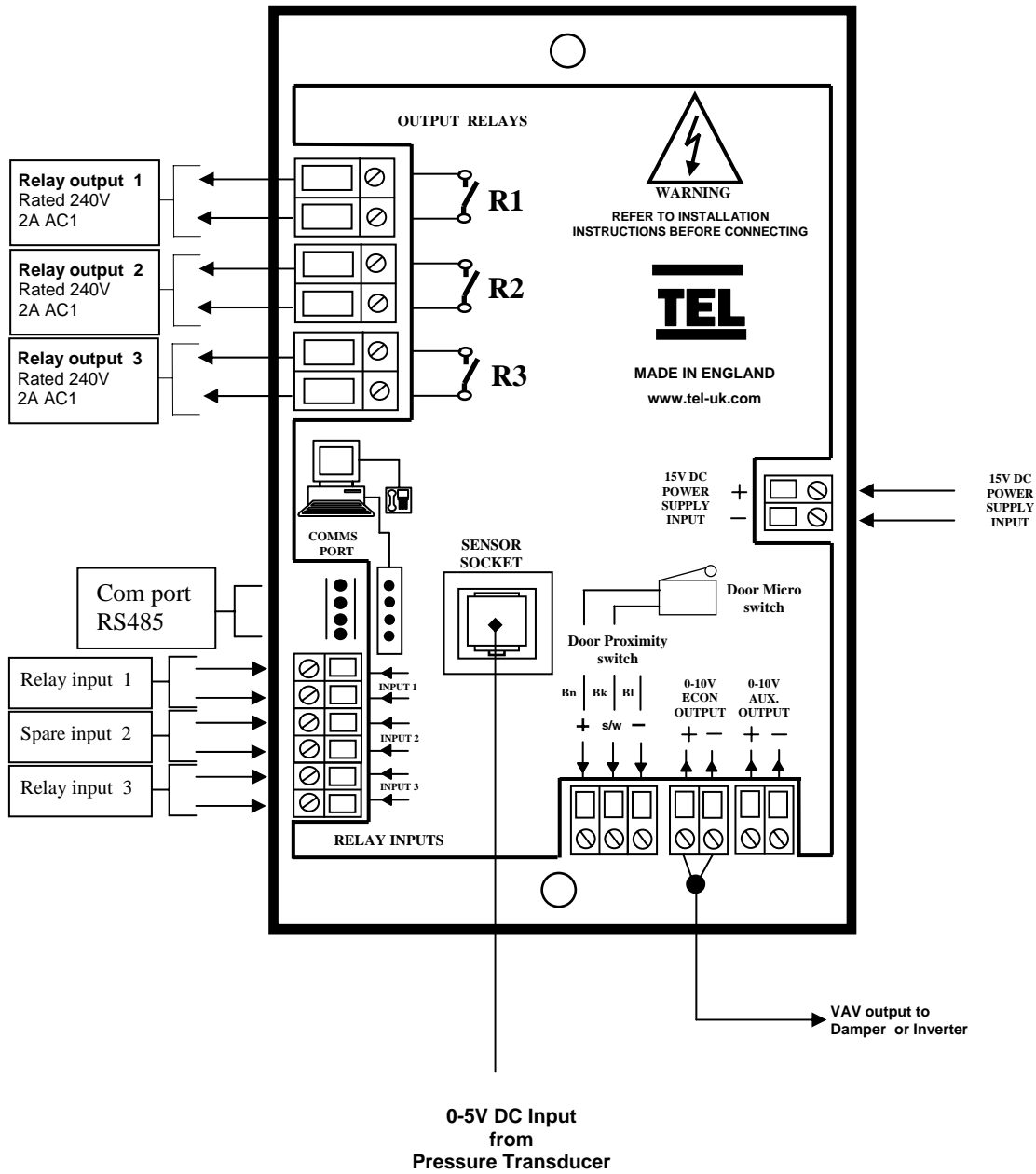

1.1 General Description

All systems comprise of the following components :-

- 1 – Pressure Transducer (Pressure range to suit the application)
- 1 – AFA1000 / E / Bld Controller / Alarm unit,
- 1 –Power supply unit
- 1 - Electrical Damper actuator (when using Damper control)

Operator Features --- the controller / alarm has the following operator features :-

Digital Display

The digital display is a back-lit, full graphic unit with a visual display of approx 56 x 27 mm. The display operates through the software allowing the generation of figures, wording and icons.

The display shows the extract system pressure in **Pa** or **ins Wg** when enabled or the alternative with no velocity reading but showing **AIR FAIL / AIR SAFE** as continuous display. All of the above are configurable via the alarm key pad.

An '**event time line**' segmented into 20 x 3 minute segments will scroll across the display (when enabled). This takes the form of a graphical 'blip' that will progress from the right hand side to the left hand side – representing events that have occurred during the past hour.

Using the diagnostics software and an associated computer via the **com port** on the alarm the event data can be transferred to a data logger.

The alternative to the event time line is a dynamic '**bar graph**' representing the **0-10V Control Output**

The display shows a **Horn** icon (with line through it) when the audible alarm is in the Muted condition

Low Pressure – will be displayed when the Extract system pressure falls below the alarm point. This display will alternate on/off with the pressure reading.

High Pressure – will be displayed when the Extract system pressure rises above the alarm point. This display will alternate on/off with the pressure reading.

Emergency – will be displayed when the Emergency input is activated (when enabled)
This display will alternate on/off with the pressure reading

Set-back - will be displayed if the night set-back function is activated (when enabled)
This display will alternate on/off with the pressure reading

LED Indicators ---- the alarm unit has three LED indicators :-

Red -- Alarm
Amber -- Caution
Green -- Safe

Audible Alarm sounder -- the alarm has an audible alarm sounder with local or remote Mute facility

Enter --- the controller / alarm has an Enter button -- this is multi-functional as follows :-

Press **Enter** momentarily when alarm is sounding will mute the alarm

Press **Enter** for 5 secs will gain access to **Calibration** and **Configuration** menus (both menus password protected)

+ / - -- the alarm has + / - buttons that can be used to scroll through the calibration and configuration menu or to select options or values

External Connections -- the alarm unit will have the following connection points :-

Input 1 --- volt free relay input configurable for normally closed or normally open relays

This input is configured as :-

Night set-back

Input 2 --- volt free relay input configurable for normally closed or normally open relays

This input is configured as :-

Emergency

Input 3 --- volt free relay input configurable for normally closed or normally open relays

This input can be configured as :-

Not Enabled

Output 1 --- volt free relay output configurable as normally closed or normally open relays.

Output 2 --- volt free relay output configurable as normally closed or normally open relays.

Output 3 --- volt free relay output configurable as normally closed or normally open relays.

Output 4 --- 0-10V (2-10V) control output – configurable direct or indirect action

Com Port --- to enable connection to Laptop or PC for full diagnostics , logging or setting up and for communications to building computer system (BMS)

Power supply --- low voltage DC power supply

Pressure Transducer --- connection socket for the pressure sensor.

1.2 Bleed Control / Alarm Configuration and Calibration

The controller / alarm can be configured via a Laptop or PC using a variety of 'set up' programs each designed for a particular application with a combination of inputs and outputs. This configuration can be changed via the alarm key pad using the menu system if required or re-configured by re-connection of the laptop or PC.

This allows the extract system manufacturer to stock standard units and configure the controller / alarms to suit the application.

The configuration of the various functions and the calibration of the controller / alarm display is menu driven. Access to the menu will be via password (4 digit number) and will be two level. The first level will be for calibration of the unit and the second level will be for 'engineers' to set up the configuration of the alarm.

**NOTE:- If you enter the Calibration or Configure Menu by accident :-
press the + & - buttons at the same time to escape back to the Main Menu**

The menus and sub-menus are in ' plain language ' and incorporate brief instructions where appropriate.

See menu operation document

1.3 Start up

When unit is powered up the following sequence of events occur :-

1. The DC power is applied to the pressure transducer and a delay on timer is initiated.
2. The alarm then performs a self test on the display and all indicators etc (approx 5 sec)
3. At the end of the delay the unit performs one of two options :-
 - a. If the alarm calibration has been previously complete – the unit goes to normal operating mode (Run)
 - b. If the unit has not been calibrated the unit displays
" Unit requires Set up -- press Enter to access Set up menu "
The set up menu allows calibration or configuration via the password protection

During the set-up all alarms and output relays are inhibited.

1.4 Events / actions

Safe Pressure

- Display reading above Low pressure alarm level and below High pressure alarm level
- Green LED on

Warning Pressure

- Display reading below Warning level and above Low pressure alarm level
- Amber LED on

Low Pressure

- Meter reads below Low pressure alarm level for longer than the delay time
- **LOW PRES.** toggles on / off with display
- Red LED on (Flashing)
- Audible alarm sounds -- can be muted via Enter pushbutton
- Low pressure relay operates (if configured)

Reset :- when pressure rises above Low pressure alarm level (including pre-set hysteresis)
the Low pressure alarm resets automatically

High Pressure (if configured)

- Meter reads above high pressure alarm level for longer than the delay time
- **HIGH PRES.** toggles on / off with display
- Audible alarm sounds – can be muted via Enter pushbutton.

Reset :- when pressure falls below High pressure alarm level (including pre-set hysteresis)
the High pressure alarm resets automatically

Night set-back

- When input configured as Night set-back is activated
- Night **SETBACK** Icon toggles on / off with display
- Unit is driven to the pre-determined **MIN** position depending on **Control function** selected (see below)
- Audible alarm muted Mute Icon shown on display

Emergency

- When input configured as Emergency is activated
- Red LED on (Flashing) – (if configured)
- **EMERGENCY** toggles on /off with display -- (if configured)
- Audible alarm sounds – can be muted via Enter pushbutton
- Emergency alarm relay operates (if configured)
- Unit is driven to the pre-determined **MAX** position depending on **Control function** selected (see below)

Note:- The external Emergency input can be a remote relay contact or a local
Emergency Stop stay-put pushbutton.

Audible alarm Mute

When the audible alarm is muted via the Enter button - an Icon (horn with forward slash) is shown on the display.

Control Function

This menu options sets the type of control for the unit to suit the application and determines how the voltage output operates in the Night setback and the Emergency conditions.

a. Action of controller :-

Direct Action ----- display value above the set point the output voltage increases => 10 V
 ----- display value below the set point the output voltage decreases => 0 V

Reverse Action ----- display value above the set point the output voltage decreases => 0 V
 ----- display value below the set point the output voltage increases => 10V

b. Min/Max and Limit settings:-

Direct Action ----- **Max** -- output voltage increases => 10 V
 ----- **Min** -- output voltage decreases => 0 V
 ----- **Upper control limit** -- output voltage increases => 10 V
 ----- **Lower control limit** -- output voltage decreases => 0 V

Reverse Action ----- **Max** -- output voltage decreases => 0 V
 ----- **Min** -- output voltage increases => 10 V
 ----- **Upper control limit** -- output voltage decreases => 0 V
 ----- **Lower control limit** -- output voltage increases => 10 V

Control Function	Control Action	Night Setback action	Emergency action
Extract Bleed Damper (Normally closed)	Direct	Drive to Min (2V) (Bleed damper closes)	Drive to min (2V) (Bleed damper closes)
Extract Fan Inverter	Reverse	Drive to Max (0V) (Extract fan to min speed)	Drive to Min (10V) (Extract fan to max speed)

2.1 Quick Start Installation

Follow the instructions below for installing and commissioning the unit. :-

1. Mount the AFA1000/E/Bld unit in a clean dry environment convenient to the Fresh Air Bleed damper or Extract fan speed control Inverter using the mounting details provided with the unit --- see page 13 & 14
2. Mount the duct Pressure transducer and connect to the extract duct using the tube and adapter provided--- see page 13 & 14
3. Connect the Mains supply , pressure transducer and bleed damper to the controls --- see typical connection diagram on page 15
4. For Inverter control --- see typical connection diagram on page 16.
5. Power up the unit and wait at least 30 secs while the system stabilises.
6. If the unit has not been calibrated the unit will display 'Requires setup' – press ENTER to continue and in the 'Main Menu' use the +/- buttons on the alarm facia to select 'SETUP' and then press the ENTER button.
7. In the Setup Menu select 'CONFIGURE' and press the ENTER button
8. At this stage you will be requested to enter the PASSWORD. Use the +/- buttons to select the individual digits in turn and then press ENTER. If the password is correct the unit will go to the 'Configure Menu'. If the password is not correct you will be requested to try again --- on the third wrong password entry the calibration menu will lock out for 10 mins
9. In the 'Configure Menu' select 'CAL Configure ' and go to 'Pressure Range' and select the pressure range to suit the pressure transducer being used . This menu also allows the Low ,Warning and High pressure alarms to be set When completed select 'Done' to return to the Main menu.

Note:- The pressure transducer is a fully calibrated unit and selecting the appropriate transducer automatically calibrates the AFA1000/E/Rm. However since we use a multi-range transducer it will be necessary to ZERO the controller pressure. In the Setup Menu select 'CALIBRATION' and press the ENTER button At this stage you will be requested to enter the PASSWORD. Use the +/- buttons to select the individual digits in turn and then press ENTER. If the password is correct the unit will go to the 'Calibration Menu'. If the password is not correct you will be requested to try again --- on the third wrong password entry the calibration menu will lock out for 10 mins
If the password is OK the display will instruct you how to ZERO the controller – (Remove the tubes from the Pressure Transducer and press ENTER – the controller will then sample the Zero point and return to the Main Menu)

10. Repeat steps 7. & 8. above to enter the Configure Menu and then select 'Control Configure' and go to 'Control Function' -- then select the function and the output range to suit the application and press Done to return to the Main Menu
The controls are now ready to be set up for the particular application -- see the Operation Notes below for the procedures for the different applications

2.2 Operation Notes :-

1. Fresh Air Bleed / Room Air Bleed Damper for VAV extract systems :-

This application is for the Fresh Air bleed or Room Air Bleed damper control on ECON VAV systems.

Before setting up the manual balancing dampers and the ECON controls on the fume cupboards the Air Bleed Damper needs to be fully closed.

To do this select Setup in the Main Menu and go to Configure via the password and then to Control Configure. In this menu select Manual/Auto and go to Manual. When in the Manual mode use the +/- buttons to drive the bleed damper closed then and press Done to return to the Main Menu and select Run .

Then complete the setting up of the fume cupboard ECON controls and set the system running at the design volume taking into account any diversity on the system. At this point the AFA1000/E/Bld will read the system pressure on the display. Note this pressure and in the Control Config menu enter the displayed pressure reading as the Set Point. Then switch the controls to the Automatic mode and press Done to return to the Main Menu and select Run .

The system will now operate automatically and maintain the extract set point pressure and thus the extract volume as the volume from the fume cupboards varies.

See **Control Settings** below for details on the fine tuning of the controls

2. Extract Fan speed control for VAV extract systems :-

This application is for the extract fan speed control on ECON VAV systems.

Before setting up the manual balancing dampers and the ECON controls on the fume cupboards the extract fan speed needs to be manually set.

To do this select Setup in the Main Menu and go to Configure via the password and then to Control Configure. In this menu select Manual/Auto and go to Manual. When in the Manual mode use the +/- buttons to set the desired speed of the extract fan then and press Done to return to the Main Menu and select Run .

Then complete the setting up of the fume cupboard ECON controls and set the system running at the design volume taking into account any diversity on the system. At this point the AFA1000/E/Bld will read the system pressure on the display. Note this pressure and in the Control Config menu enter the displayed pressure reading as the Set Point. Then switch the controls to the Automatic mode and press Done to return to the Main Menu and select Run .

The system will now operate automatically and maintain the extract set point pressure as the ECON controls on the fume cupboards vary the volume extracted from the lab.

See **Control Settings** below for details on the fine tuning of the controls

2.2 Control Settings :-.

1. There are various operational setting that need to be set to give good control of the extract duct pressure. These setting are adjustable in the 'Control configure menu'. Due to the possible variations in the applications each unit will be supplied with a printed sheet giving the values of the parameters as set in the factory before despatch.(These can also be viewed using a Laptop computer plugged into the 'Com port'). The factory settings are based on previous experience of similar installations but may require some adjustment to suit the particular installation.(These setting should only be adjusted by experienced engineers familiar with controls and the requirements of the fume cupboard installations.)

2. Certain parameters can be pre-set from knowledge of the installation :-

Set point ---	This is the desired extract duct pressure (during commissioning)
Damper / Inverter ---	For systems with bleed damper control or variable speed extract fan using an Inverter
Output range ---	2-10V or 0-10V depending on what is being controlled

3. Certain parameters can be adjusted (in small increments) to improve the stability and performance of the control :-

Stability --- the stability of the system can be effected by two main items – turbulent airflow across the face of the pressure sensor or the 'sensitivity' of the control loop. It is important to establish the cause of the problem before attempting to adjust any parameters.

To do this put the control system into 'Manual' operation and check the stability of the measured pressure. In this condition the bleed damper or Inverter will be at a fixed position so any instability seen will be due to the extract system or to turbulent air across the sensor. This can be check and corrected.

If the system is stable in the 'Manual mode' the problem could be due to the control sensitivity being too high. The sensitivity is set by the '**Prop Band**' in the 'Control config menu'. This can be increased to reduce the sensitivity.

Performance --- to reduce the time for the measured value to go to the set point value (ie removal of the 'offset') after a change in duct pressure the '**Integral time**' in the 'Control config menu' can be increased. This is normally set to 60 reps/min

4. **MIN** --- This is a manual fixed position select by the Night set-back activation and can be adjusted to the desired value.
MAX --- This is a manual fixed position select by the Emergency activation and can be adjusted to the desired value.
Low limit - This is used to limit the travel of the damper in the opening position or the min speed of the extract fan to maintain the desired extract rate from the fume cupboards in normal operation as the sashes are closed.
High limit - This is used to limit the travel of the damper in the closing position or the max speed of the extract fan to maintain the desired max extract rate from the fume cupboard in normal operation as the Sash is opened.

Note :- The above information is a guide only on how to set up and calibrate the controls incorporating the AFA1000 / E / Bld controller.

Most VAV fume cupboard installations use a common extract fan complete with a fresh air bleed system connected to multiple fume cupboards. It is important to consider the commissioning and setting up of the system as a whole before attempting to set up the individual controls.

3.0 Dimensions

Enclosure with Hinged Lid
(Hinges on Left Hand Side)

Cable knock outs

3 x M20 Top
3 x M20 Bottom

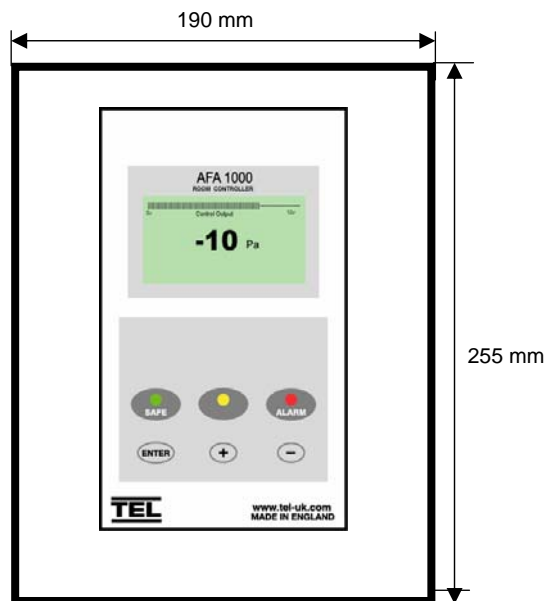

Enclosure Dimensions

255mm x 190mm x 110 mm Deep

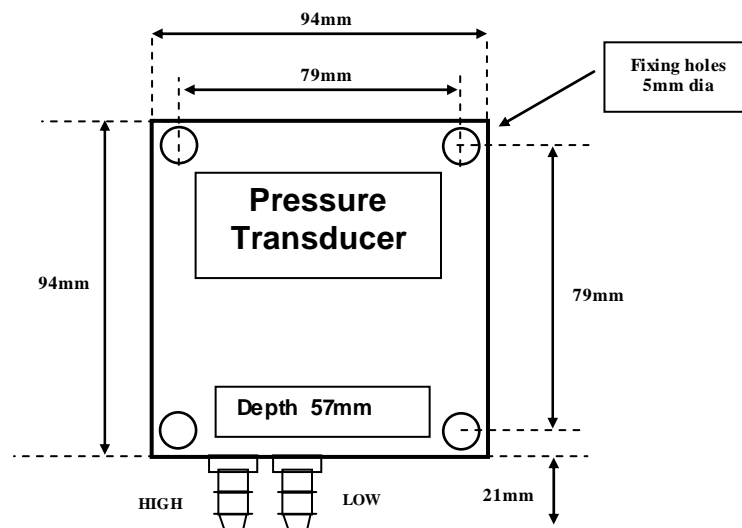

Pressure Transducer Notes :-

1. The transducer should be mounted vertically using the fixing lugs with the tube and cable connections at the bottom.
2. The transducer is rated to IP66 and is suitable for installation outside providing that the cable connection gland is weather proof

NOT TO SCALE

4.0 Extract Air Bleed Damper Controls Installation

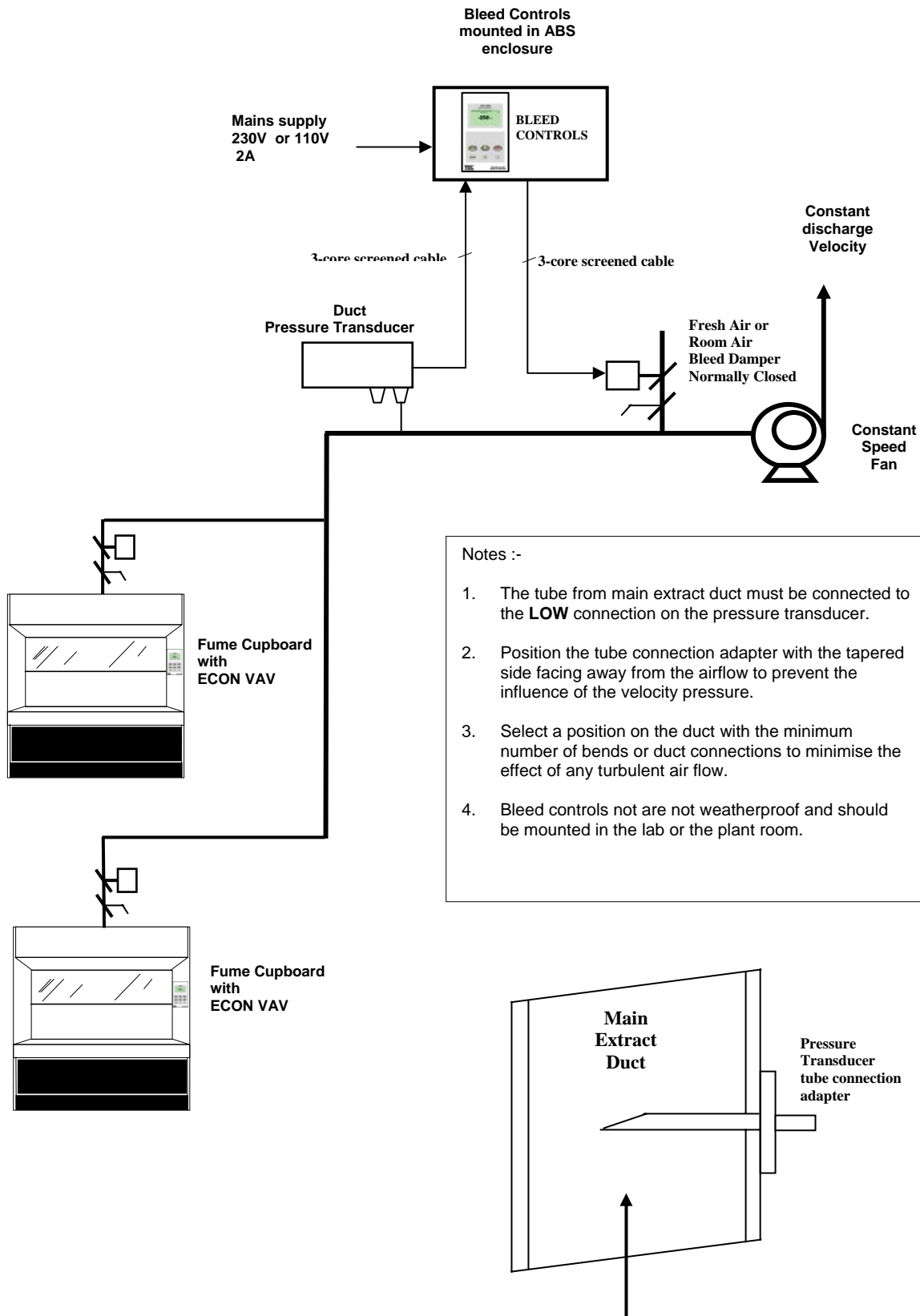

Notes :-

1. The tube from main extract duct must be connected to the **LOW** connection on the pressure transducer.
2. Position the tube connection adapter with the tapered side facing away from the airflow to prevent the influence of the velocity pressure.
3. Select a position on the duct with the minimum number of bends or duct connections to minimise the effect of any turbulent air flow.
4. Bleed controls are not weatherproof and should be mounted in the lab or the plant room.

4.1 Extract Fan Inverter Speed Controls Installation ^{Airflow}

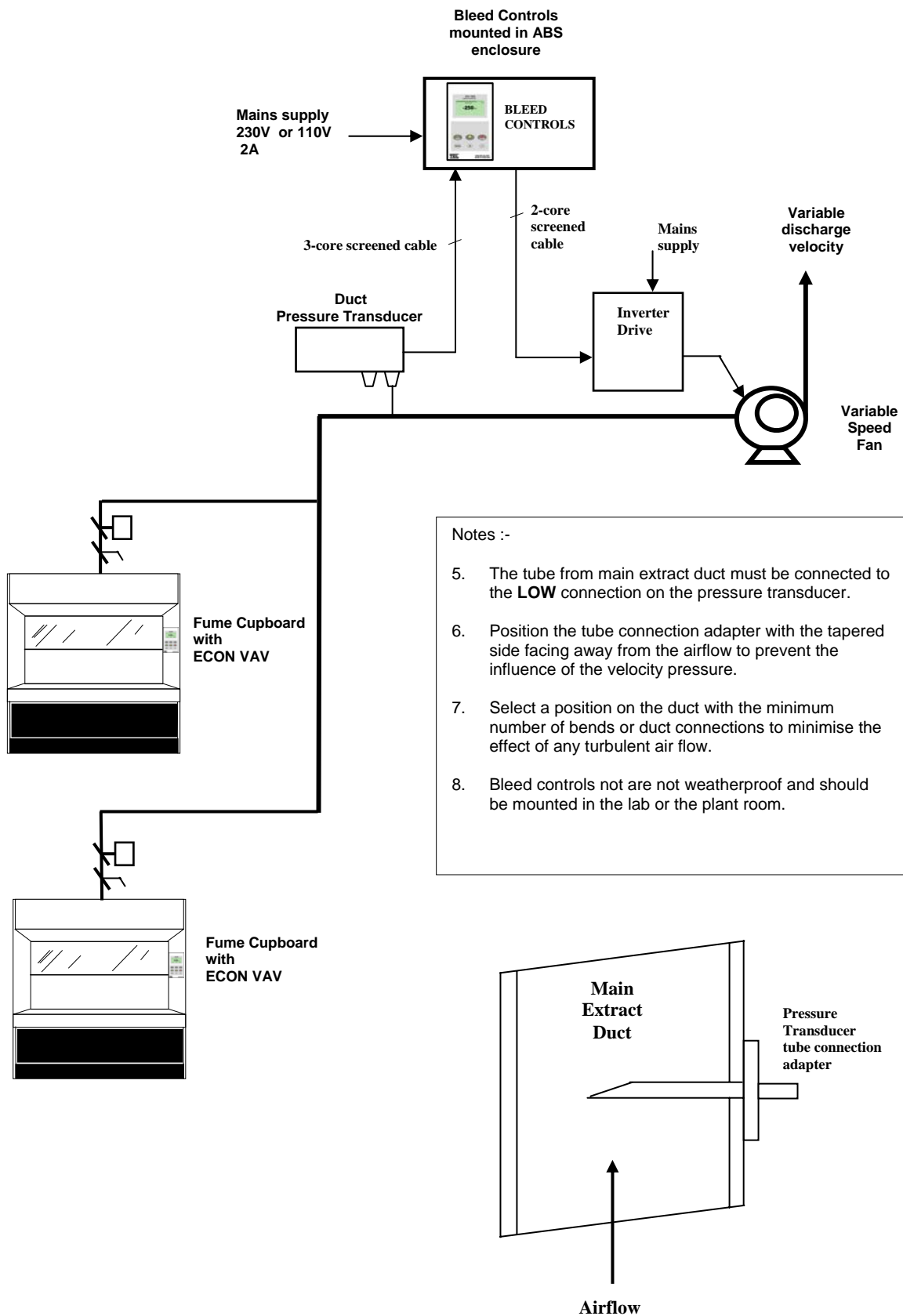

5.0 Typical Wiring Diagram – DAMPER CONTROL

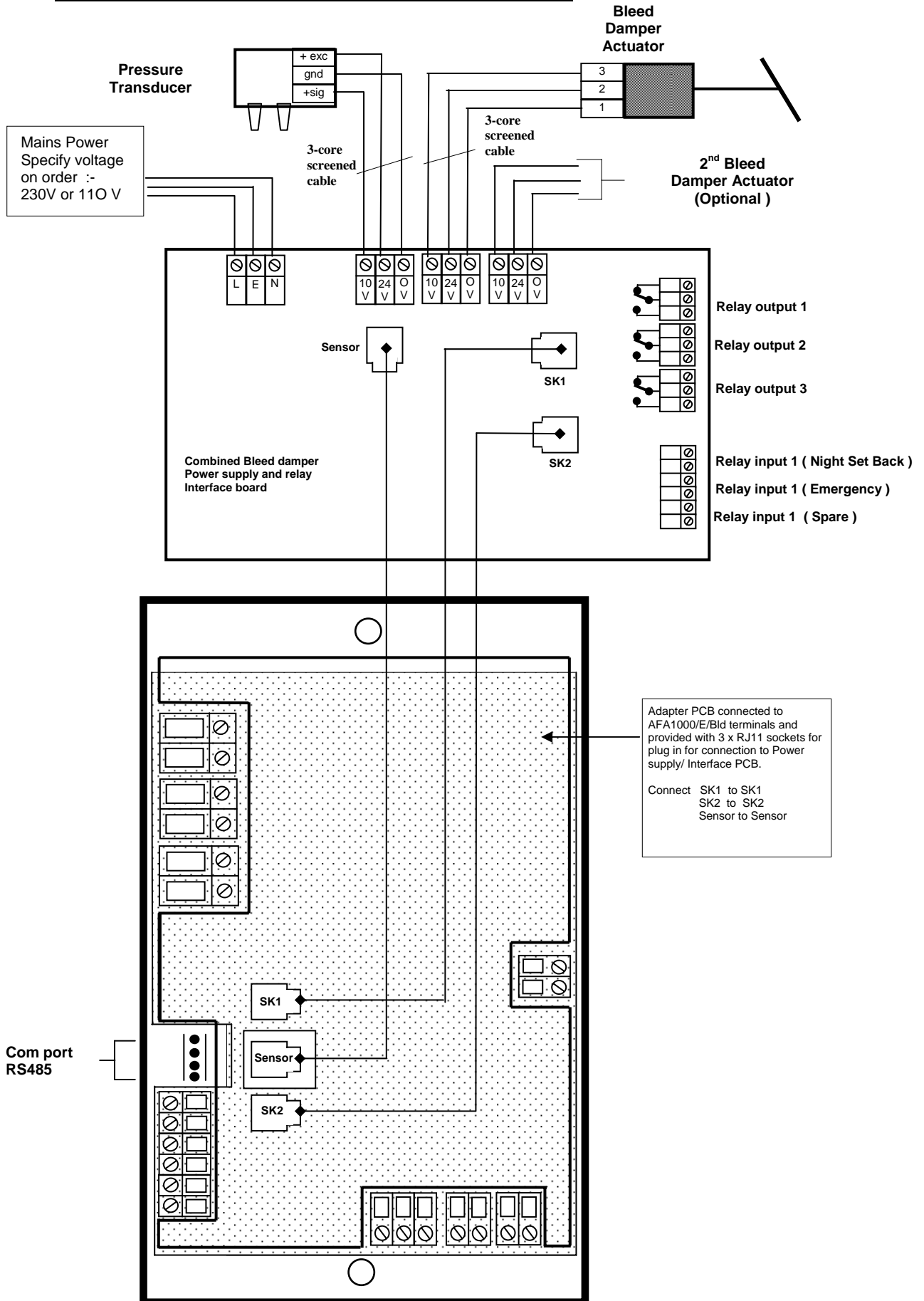

5.2 Typical Wiring Diagram – INVERTER CONTROL

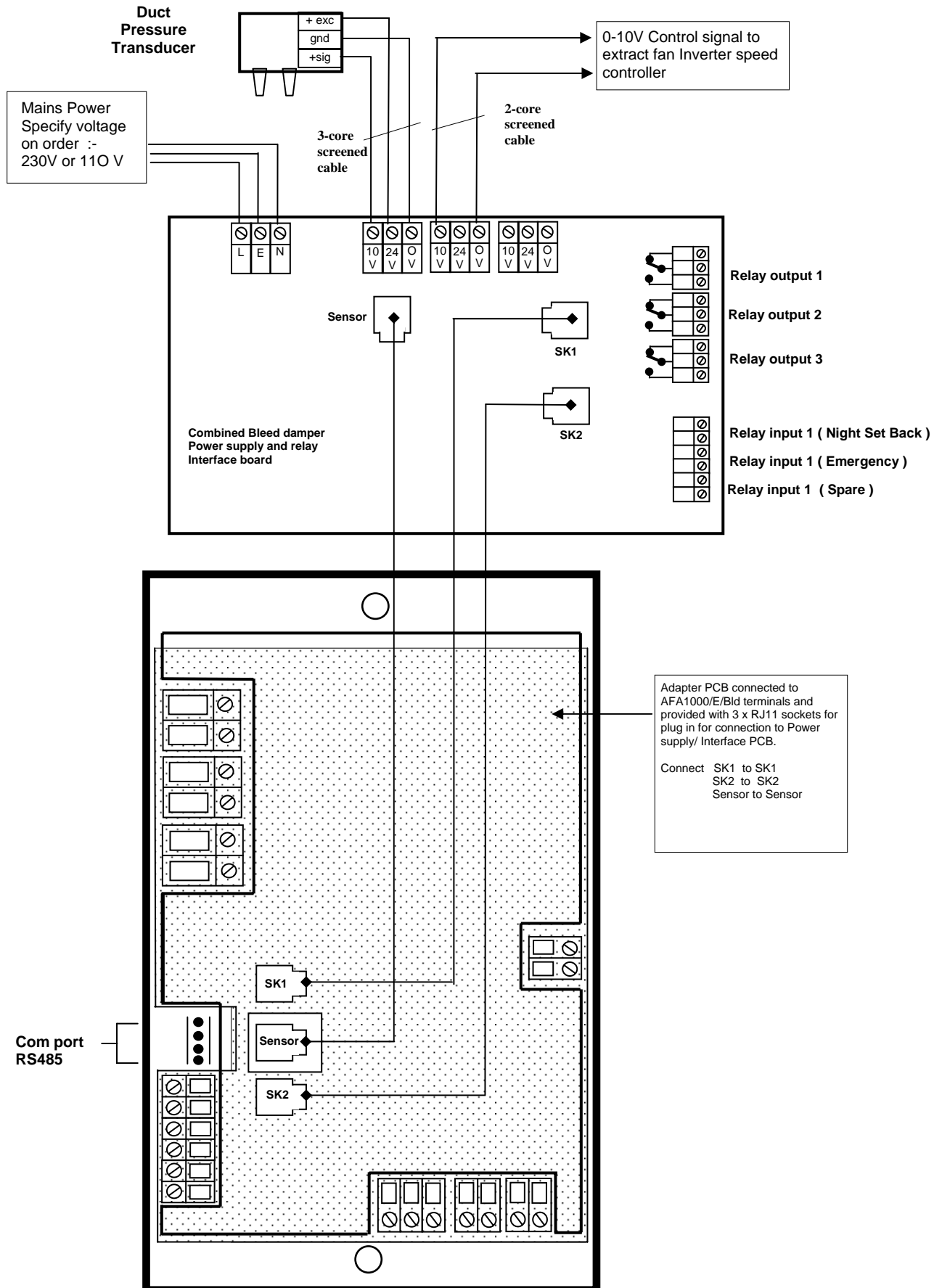

6.0 Limitation of Warranty and Liability

Seller warrants that this product, under normal use and service as described in the operator's manual shall be free from defects in workmanship and material for a period of twelve (12) months, or the length of time specified in the operator's manual, from the date of shipment to the customer. This limited warranty is subject to the following exclusion :-

- a. Batteries and certain other components when indicated in specifications are warranted for a period of 90 days from the date of shipment to the customer.
- b. With respect to any repair services rendered, Seller warrants that the parts repaired or replaced will be free from defects in workmanship and material, under normal use, for a period of 90 days from the date of shipment to the customer
- c. Seller does not provide any warranty on finished goods manufactured by others. Only the original manufacturer's warranty applies.
- d. Unless specifically authorised in a separate writing by Seller, Seller makes no warranty with respect to, and shall have no liability in connection with, any goods which are incorporated into other products or equipment by the Buyer. All goods returned under warranty shall be at the Buyer's risk of loss, Seller's factory prepaid, and will be returned at Seller's risk of loss, Buyer's factory prepaid.

The foregoing is IN LIEU OF all other warranties and is subject to the conditions and LIMITATIONS stated herein. NO OTHER EXPRESS OR IMPLIED WARRANTY OF FITNESS FOR PARTICULAR PURPOSE OR MERCHANTABILITY IS MADE.

THE EXCLUSIVE REMEDY OF THE USER OR PURCHASER, AND THE LIMIT OF LIABILITY OF SELLER FOR ANY AND ALL LOSSES, INJURIES, OR DAMAGES IN CONNECTION WITH THIS PRODUCT (INCLUDING CLAIMS BASED ON CONTRACT NEGLIGENCE, STRICT LIABILITY, OTHER TORT, OR OTHERWISE) SHALL BE THE RETURN OF THE PRODUCT TO THE FACTORY OR DESIGNATED LOCATION AND THE REFUND OF THE PURCHASE PRICE, OR, AT THE OPTION OF THE SELLER, THE REPAIR OR REPLACEMENT OF THE PRODUCT. IN NO EVENT SHALL SELLER BE LIABLE FOR ANY SPECIAL, INCIDENTAL OR CONSEQUENTIAL DAMAGES. SELLER SHALL NOT BE RESPONSIBLE FOR INSTALLATION, DISMANTLING, REASSEMBLY OR REINSTALLATION COSTS OR CHARGES. NO ACTION, REGARDLESS OF FORM, MAY BE BROUGHT AGAINST THE SELLER MORE THAN ONE YEAR AFTER THE CAUSE OF ACTION HAS ACCRUED.

The purchaser and all users are deemed to have accepted the terms of this LIMITATION OF WARRANTY AND LIABILITY, which contains the complete and exclusive limited warranty of Seller. This LIMITATION OF WARRANTY AND LIABILITY may not be amended or modified nor may any of its terms be waived except by a writing signed by an authorised representative of the Seller.

7.0 Contact us :-

**For further information on our range of airflow alarms and controls
please contact us at :-**



TEMPERATURE ELECTRONICS Ltd

388 / 400 MANCHESTER ROAD

ROCHDALE

LANCS , ENGLAND

OL11 4NW

Tel : +44 1706 633438 Fax : +44 1706 524609

Web site: www.tel-uk.com